

Simultaneous 3D Machining with Real-Time NURBS Interpolation

Won-Pyo Hong*, Seok-Woo Lee, Hon-Zong Choi

*Manufacturing System Research Center/Nano Machining Team,
Korea Institute of Industrial Technology (KITECH), Chungnam 330-825, Korea*

Min-Yang Yang

*Department of Mechanical Engineering,
Korea Advanced Institute of Science and Technology (KAIST), Teajon 305-701, Korea*

Increasing demand on precision machining using computerized numerical control (CNC) machines have necessitated that the tool move not only with the smallest possible position error but also with smoothly varying feedrates in 3-dimensional (3D) space. This paper presents the simultaneous 3D machining process investigated using a retrofitted PC-NC milling machine. To achieve the simultaneous 3-axis motions, a new precision interpolation algorithm for 3D Non-Uniform Rational B-Spline (NURBS) curve is proposed. With this accurate and efficient algorithm for the generation of complex 3D shapes, a real-time NURBS interpolator was developed using a PC and the simultaneous 3D machining was accomplished satisfactorily.

Key Words : NURBS ; Interpolation ; CNC ; PC-NC ; Reference-Pulse Interpolator

1. Introduction

Since the development of NC, machining of curved surfaces has been a challenging task due to the increasing demand on precision and productivity. Most Computer-Aided Design (CAD) systems provide the designer with tools for defining 3D sculptured surfaces. In contrast, CNC machines basically support only the functions of linear and circular interpolations. Thus the surfaces have to be machined as a collection of linear or circular segments within the specified tolerance requirements.

There are several problems with this process. The segmentation process reduces the accuracy of the finished part. Since the curve is represented by

many small segments, the resulting part program is long and a lot of storage space is required. Most CNC cannot process this large amount of data fast enough to keep up with the high feed rate. The consequence of this shortcoming is jerky motion caused by starvation of the command data. The only solution to this problem is either to make the segments longer or to slow down the feed rate (Yeh and Hsu, 1999 ; Chou and Yang, 1991).

When a CNC has a NURBS interpolation function, many problems associated with processing linear or circular segment can be eliminated. Only the conversion process is needed to generate the NURBS formatted part program. The interpolation of the NURBS curve is then done in the CNC. Thus the accuracy of the part is improved and the resulting part program is much shorter. Also the productivity of the machine is improved because of the faster acceleration and deceleration time of the smooth curve versus the curve made up of many small segments (Zhang and Greenway, 1998 ; Scherer, 1997 ; Kiritsis, 1994).

* Corresponding Author.

E-mail : wonpyodr@kitech.re.kr

TEL : +82-41-589-8276; FAX : +82-41-589-8260

Manufacturing System Research Center/Nano Machining Team, Korea Institute of Industrial Technology (KITECH), 35-3, HongChon-Ri, IbJang-Myun, Chon-An, Chungnam 330-825, Korea. (Manuscript Received April 13, 2002; Revised December 10, 2002)

value of the first derivatives is required, the first derivative of Eq. (3) is modified as follows.

$$(\bar{C}^i(u))' = U_p^i N_p^i w R_p^i - C^i(u) \cdot U_p^i N_p^i w_p^i \quad (4)$$

STEP 2: For the step movement in the master axis, the corresponding new value of the parameter u is calculated. In general, this can be obtained by using a numerical method. However the numerical method takes time to converge. Hence the new value of parameter u is evaluated from the previous u and the first derivative value as shown in Eq. (5) based on the fact that the step movement in the master axis is always generated. The sign of the increment is decided by the direction of motion in the master axis. As shown in Eq. (3), a degree p NURBS curve segment can be obtained from the $p+1$ control points. By resetting the starting value of u to 0 for each curve segment and taking a true value of u for the case where the master axis is changed, the accumulation of error is restricted.

$$u_{new} \approx u_{previous} - \frac{C^i(u_{previous}) - C_{new}}{(C^i(u_{previous}))'}$$

$$= u_{previous} - \frac{\mp BLU}{(C^i(u_{previous}))'} \quad (4)$$

STEP 3: Using the calculated value of parameter u , the step movements in the slave axis (except a master axis) are decided. By comparison with the true coordinate values of each slave axis as shown in Eq. (6), the motion that has the maximum error within 0.5BLU for each axis is selected. The above 4 possible steps are reduced to 1 step that has the minimum path error. The sign of each increment is decided by the given direction along the curve.

$$C_{new} = \begin{cases} C_{previous} \pm BLU, & \text{if } |C^i(u_{new}) - C_{previous}| \geq 0.5BLU \\ C_{previous}, & \text{otherwise} \end{cases} \quad (6)$$

STEP 4: The selected step movements in 1-master and 2-slave axis are generated to produce the simultaneous 3-axis motion.

STEP 5: The above successive interpolation process is repeated until the terminal point of the

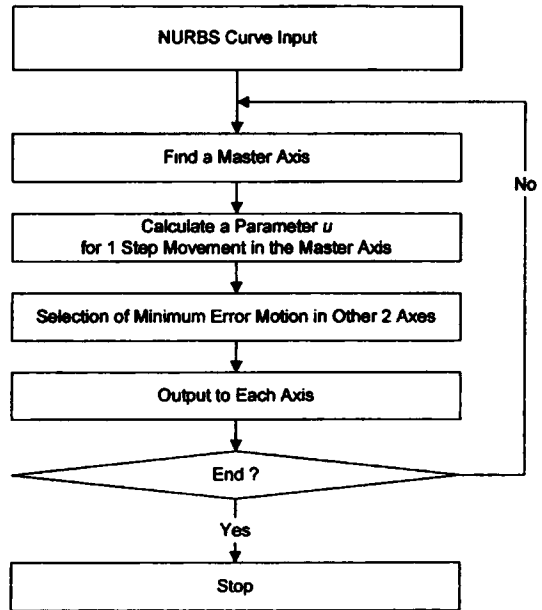

Fig. 1 Real-time NURBS interpolation algorithm

NURBS curve is reached. Since each NURBS curve segment is defined in the interval $u \in [0, 1]$, the examining a final value of the parameter u is used as the stopping criteria. By checking the end condition of a final curve segment, the entire interpolation process shown in Fig. 1 is terminated.

Fig. 2 shows a test free form curve of the proposed 3D NURBS interpolation in visible step. Quite a large step is used in order to show how the interpolation algorithm generates the incremental steps. Also each result on the 2D planes (X - Y , X - Z and Y - Z plane) is designated to validate how well the interpolation is executed. It can be seen that the interpolated path does not diverge by more than one step from the ideal NURBS curve.

There are special NC commands that put the CNC into NURBS interpolation mode (Wallace, 1997; Hasenjaeger, 1999). Through the comparison of previous various formats, new NC formats for NURBS commands that have improved efficiency and are compatible with existing conventions for ordinary (linear and circular) G codes are designed as shown in Table 1. G05.1 command processes the control points, weights

Table 1 Input format for 3D NURBS interpolator

	Part program	Character
NURBS format 1	G05.1 P_X_Y_Z_K_W_F_	X, Y, Z : control points
	X_Y_Z_K_W_	P : order
	...	W : weight
NURBS format 2	G05.2 P_X_Y_Z_F_	X, Y, Z : data points
	X_Y_Z_	P : order
	...	
	X_Y_Z_	

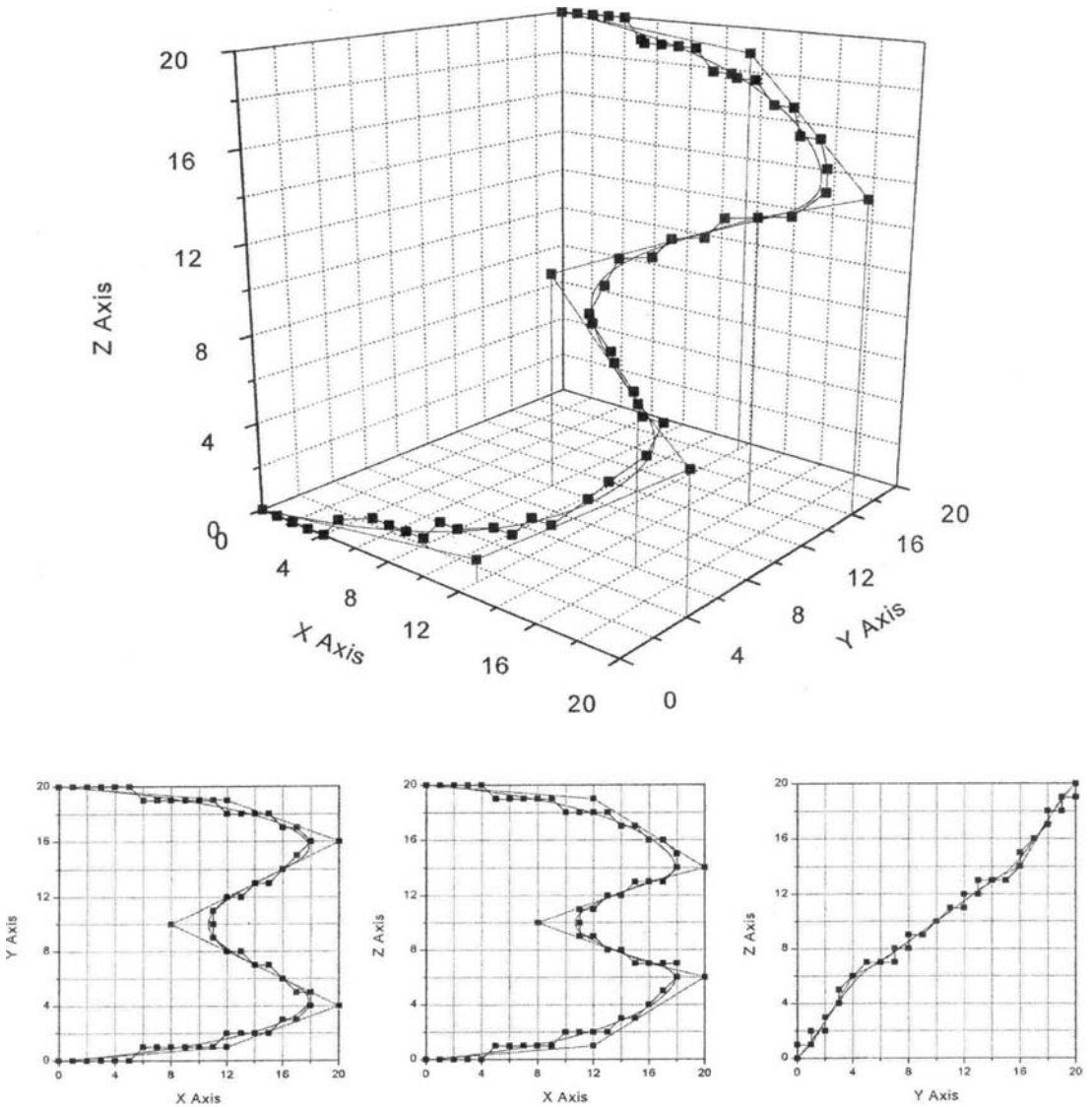

Fig. 2 3D path along the test curve

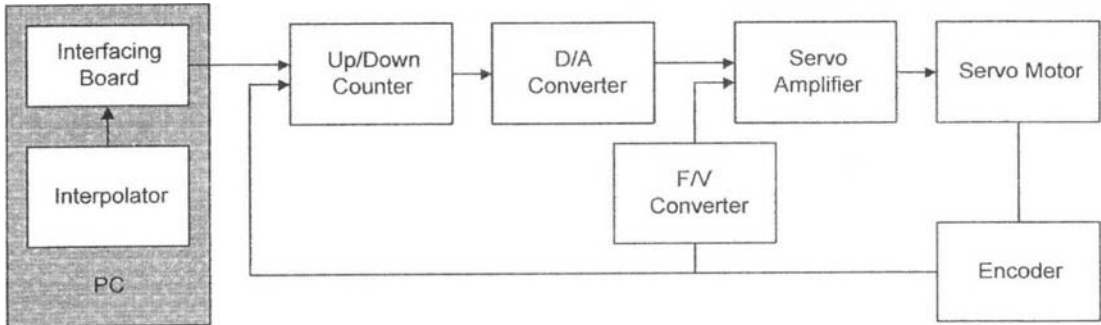

Fig. 3 Block diagram of a single-axis closed loop system

and knot vector, and the last point of previous block is used as the first control point of the current curve. G05.2 command processes the exact data points (not the control points) of NURBS curves. Since G05 is unsigned in the ISO 6983-1 standard (ISO, 1982), this paper adopts it to specify the NURBS curve tool paths and the associated feed rate functions.

3. PC-NC Milling Machine

CNC machine tools have been widely used in order to improve the machining accuracy and increase productivity. As the CNC machine tools play a central role in manufacturing processes, the replacement to new machines with advanced technology is needed. As an alternative plan for enhancing the capability of the existing machines economically, the reconfiguration of the available old ones is presented. In reconfiguration, a PC is often used as the machine control unit (MCU) (Huang and Lee, 1993; Luscombe et al., 1994). By using a PC, the new software modules for the advanced technology can be developed and added to the machine tools easily.

To achieve the simultaneous 3D machining, the reconfiguration to a 3-axis PC-NC milling system from a traditional milling machine is accomplished. Reconfiguration is mainly executed in the transmission and the control system under the same mechanical structure. Three AC servomotors are used as the actuator to operate the machine, and the ball-screws are used as the transmission mechanism of the machine tool table.



Fig. 4 3-axis PC-NC milling machine

The block diagram shown in Fig. 3 is used to develop a reference pulse type PC-NC milling machine. The up/down counter compares the reference pulses from the PC with the feedback pulses from the encoder. The counter generates a digital value representing the instantaneous position error in pulse units. The value is converted to a voltage by the digital to analog (D/A) converter, which is applied to the servo amplifier. The amplifier has a velocity feedback through a frequency to voltage (F/V) converter. In order to interface with the PC an interfacing board is plugged into the expansion slot. The programmable peripheral interface (PPI: i82C55) chips are used to convert the pulse commands from the interpolator into electrical signals. The BLU of the developed milling machine is $1\ \mu\text{m}$.

4. Experimental Results and Discussion

In order to evaluate the performance of the

real-time 3D NURBS interpolation algorithm and the developed 3-axis PC-NC milling system, several experiments were carried out.

The basic requirement for the interpolators is the generation of the reference commands to drive the machine tools. Therefore, the interpolation error is evaluated as the normal distance from the interpolation position to the given NURBS curve. In general, the maximum error is smaller than one step (1BLU). From the various command inputs to the 3D NURBS interpolator, it is found that the maximum interpolation error is 0.707BLU. In case of the straightforward application to 2D curves, the maximum interpolation error is reduced to 0.5BLU. These results are caused by the limitation of the maximum error in each axis which is 0.5BLU.

Reference pulse interpolators have a restriction on the maximum axis velocity imposed by the interpolation execution time. Therefore, the iteration time ($\mu\text{sec}/\text{step}$) is calculated by totaling the execution times of the individual instructions in the interpolation routine, and the maximum cutting feed rate is obtained from the iteration time and the specification (1BLU = $1\mu\text{m}$) of the PC-NC milling machine (Table 2). Taking into account the fact that computer performance continues to increase rapidly, the provided maximum cutting feed rate is reasonable.

The effectiveness of the developed system is evaluated by comparing the program file size of NC commands required for the same paths. For the machining of free form surfaces as shown Fig. 5, the new NURBS format G05.1 reduces the program file size by 22% and 11% relative to the previous format of Fanuc (G06.2) and Siemens (BSPLINE), respectively. Also G05.2 blocks can process the exact data points (the control points) of the NURBS curves. These new NC formats allow successful communication of NURBS data with much smaller part programs and higher accuracy.

The result of the simultaneous 3D machining is shown in Fig. 5. The parts are machined from $50 \times 100 \times 50$ mm duralumin blocks using a HSS ball end mill cutter having a diameter of 8 mm. In contrast to the machining of linear segments, the

Table 2 Maximum feed rate of the PC-NC milling machine (Intel Pentium III 500 processor)

	NURBS interpolation
Iteration time ($\mu\text{sec}/\text{step}$)	6.28
Feed rate (m/min)	9.55

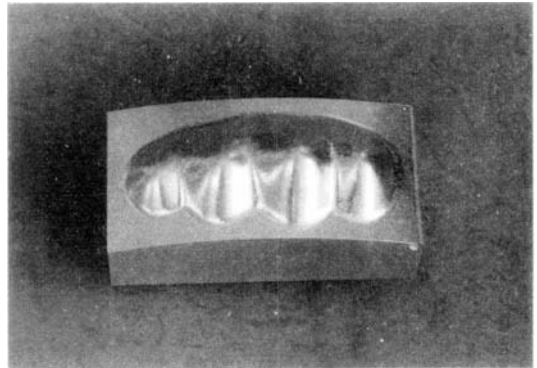

Fig. 5 Simultaneous 3D machined surface

number of NC blocks is reduced by 37%. Therefore the developed PC-NC milling system generates the 3D complex-shaped paths itself without using linear or circular segment, and the full accomplishment of the performance of 3-axis machine tools for precision machining is possible.

5. Conclusions

This paper presents the simultaneous 3D machining with NURBS interpolation. A real-time reference pulse 3D NURBS interpolator based on the searching for minimum path error strategy was developed in the software, and this was implemented in the framework of the retrofitted PC-NC milling machine.

Several experimental results have shown that the interpolation error does not exceed the machine tool resolution with the reasonable machining speed, and the proposed system is efficient for the generation of NURBS motions. From the machined part with 3D free form paths, it has been shown that the PC-NC milling machine with presented interpolation algorithm is useful for the machining of complex 3D shapes. It is expected that this can be applied to the CNC systems for precision 3D machining.

References

- Choi, B. K., 1991, *Surface modeling for CAD/CAM*, Elsevier.
- Chou, J. J. and Yang, D. C. H., 1991, "Command Generation for Three-Axis CNC Machining," *ASME Journal of Engineering for Industry*, Vol. 113, pp. 305~310.
- Hasenjaeger, B., 1999, "NURBS, CAD/CAM, CNC: Who's in Charge?," *Integrated Manufacturing Solutions*, pp. 18~19, March.
- Huang, S. J. and Lee, C. F., 1993, "Servo-Drive Systems for Milling Machine Retrofit Application," *Int. J. of Machine Tools & Manufacture*, Vol. 33, No. 3, pp. 449~463.
- ISO Standard 6983-1, 1982, "Numerical Control of Machines-Program Format and Definition of Address Words," *International Organization for Standardization*.
- Kiritsis, D., 1994, "High Precision Interpolation Algorithm for 3D Parametric Curve Generation," *Computer-Aided Design*, Vol. 26, No. 11, pp. 850~856.
- Koren, Y., 1983, *Computer Control of Manufacturing Systems*, McGraw-Hill, pp. 115~142.
- Luscombe, A. M., Toncich, D. J., Thomson, W. and Dluzniak, R., 1994, "A New Type of Machine Control System to Replace Traditional CNC," *Int. J. of Advanced Manufacturing Technology*, Vol. 9, pp. 369~374.
- Piegl, L. and Tiller, W., 1995, *The NURBS book*, Springer.
- Scherer, J., 1997, "High Speed, High Precision Machining with NURBS Interpolation," *2nd Int. Machining & Grinding Conference*, Michigan, pp. 707~716.
- Wallace, J., 1997, "NURBS in a nutshell," *Manufacturing Engineering*, pp. 92~98, October.
- Yang, M. Y. and Hong, W. P., 2002, "Three-Dimensional Reference Pulse Linear and Circular Interpolators for CNC Systems," *Int. J. of Production Research*, Vol. 40, No. 2, pp. 425~439.
- Yeh, S. S. and Hsu, P. L., 1999, "The Speed-Controlled Interpolator for Machining Parametric Curves," *Computer-Aided Design*, Vol. 31, pp. 349~357.
- Zhang, Q. G. and Greenway, R. B., 1998, "Development and Implementation of a NURBS Curve Motion Interpolator," *Robotics & Computer-Integrated Manufacturing*, Vol. 14, pp. 27~36.